



Lock case 5336/8 - Latch Lock case

TO ORDER you must specify:

- lock case number
- direction of opening, i.e. right or left
- single pack or industrial pack of 20 pcs

Application:

- meets all fire class requirements
- suitable for corrosive environments
- antifriction latch
- no locking mechanism

Operation:

- operated by handles
- antifriction latch bolt prevents vibrating

Materials and Finish:

- lock case - stainless steel
- striker plate - stainless steel
- handle hub and latch bolt - stainless steel
- 8 mm handle hub
- weighs 472 g

Delivery:

- lock case only
- striker plate is optional
- accessories must be ordered separately

Spare Parts:

1. Latch bolt retracting arm
2. Latch bolt R/L
3. Pin spring
4. Handle hub spring
5. Spring guide
6. Handle hub 8 mm
7. Latch bolt spring



Lock case 5336/8

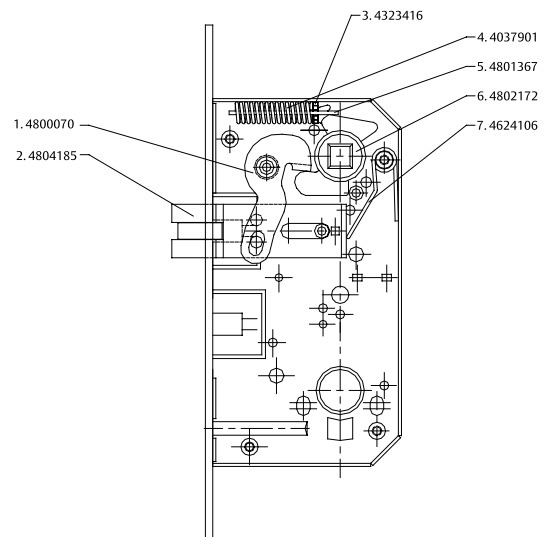

Exploded view of available spare parts

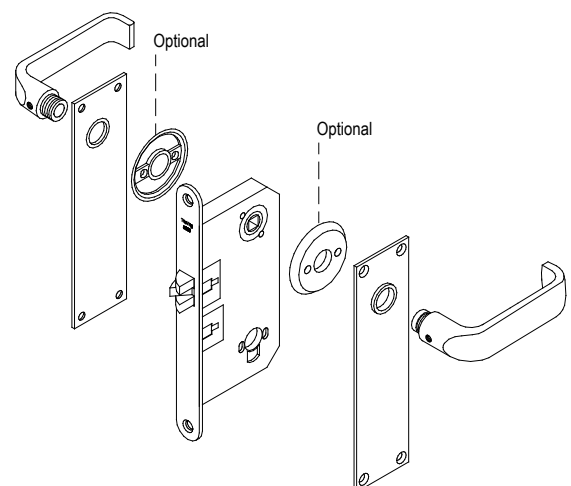

Lock case with available accessories